

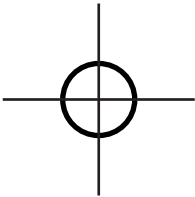

wheel pattern - Part A  
(cut from 3/4" plywood)

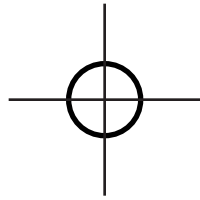



wheel pattern - Part B  
(cut from 3/4" plywood)

frame pattern - Part A  
(cut from 1/2" plywood)

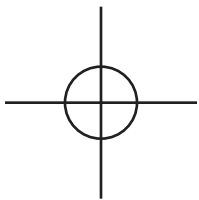



frame pattern - Part B  
(cut from 1/2" plywood)



frame pattern - Part C  
(cut from 1/2" plywood)

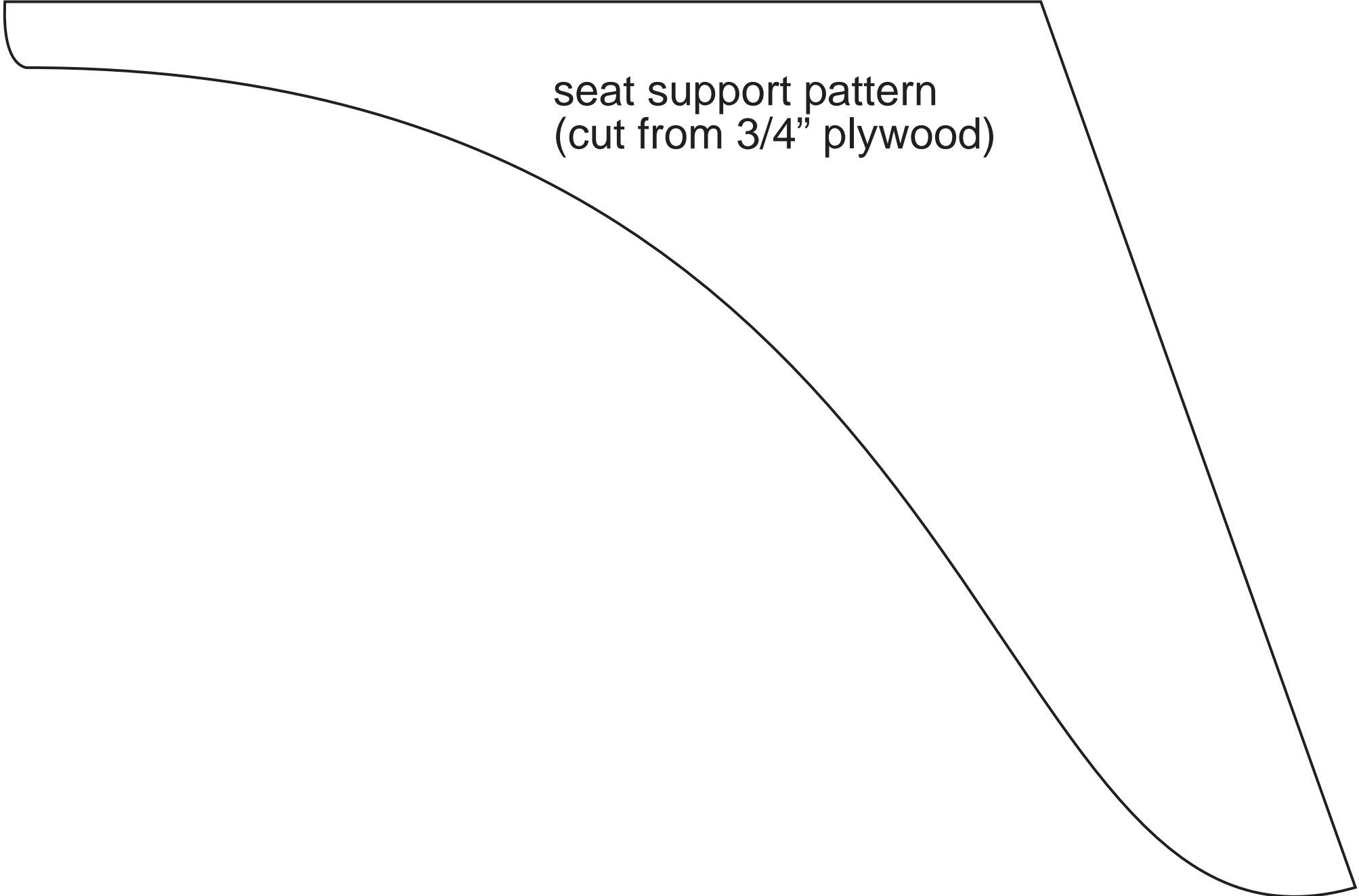

seat support pattern  
(cut from 3/4" plywood)

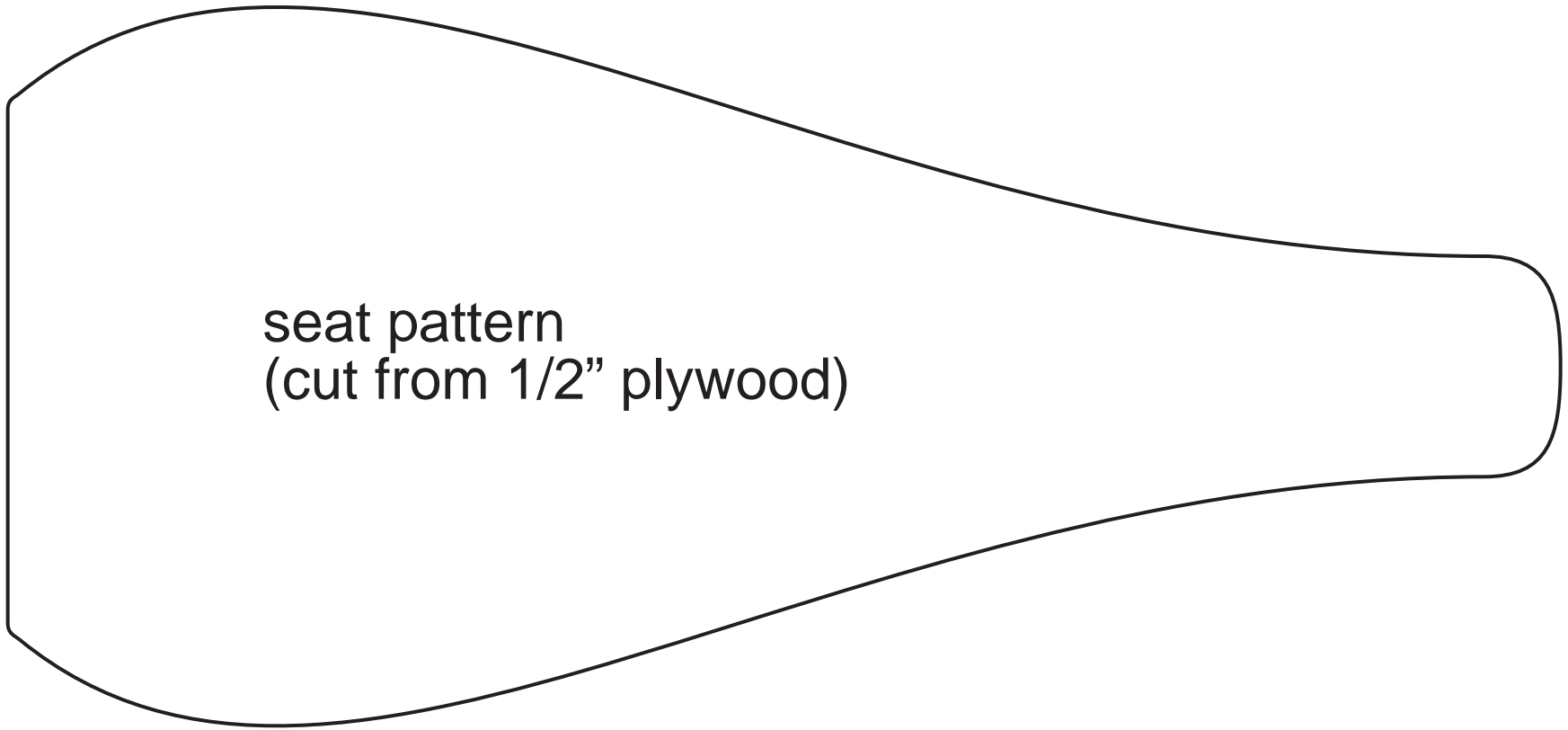

seat pattern  
(cut from 1/2" plywood)



front fork pattern - Part A  
(cut from 3/4" plywood)



front fork pattern - Part B  
(cut from 3/4" plywood)

# The Bike Frame

cut sections of 1 1/4" dowel to use as a spacers between the wheel and the frame.

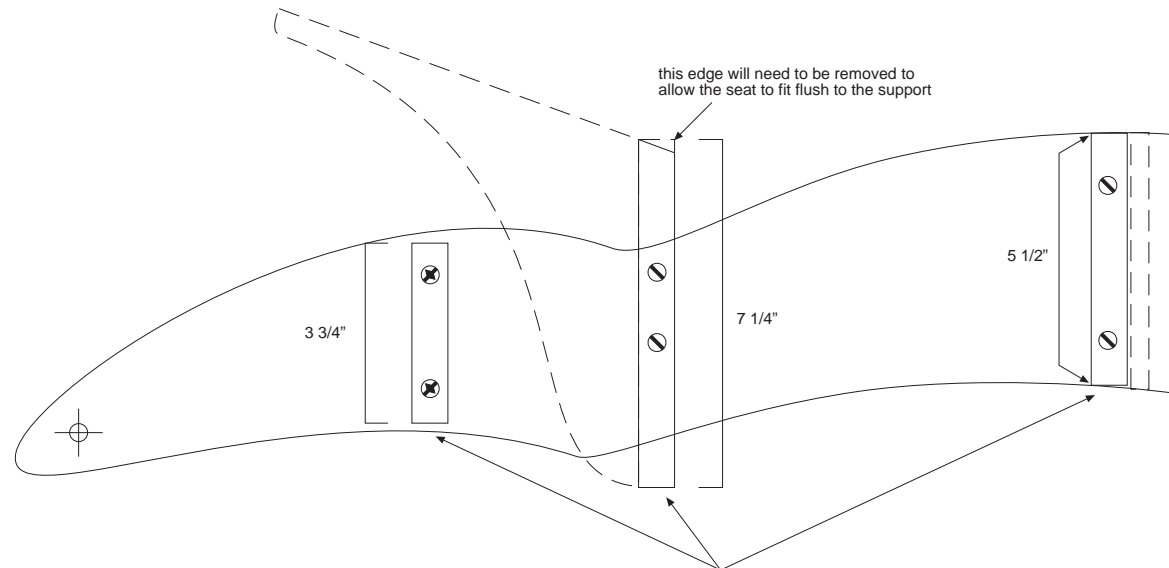
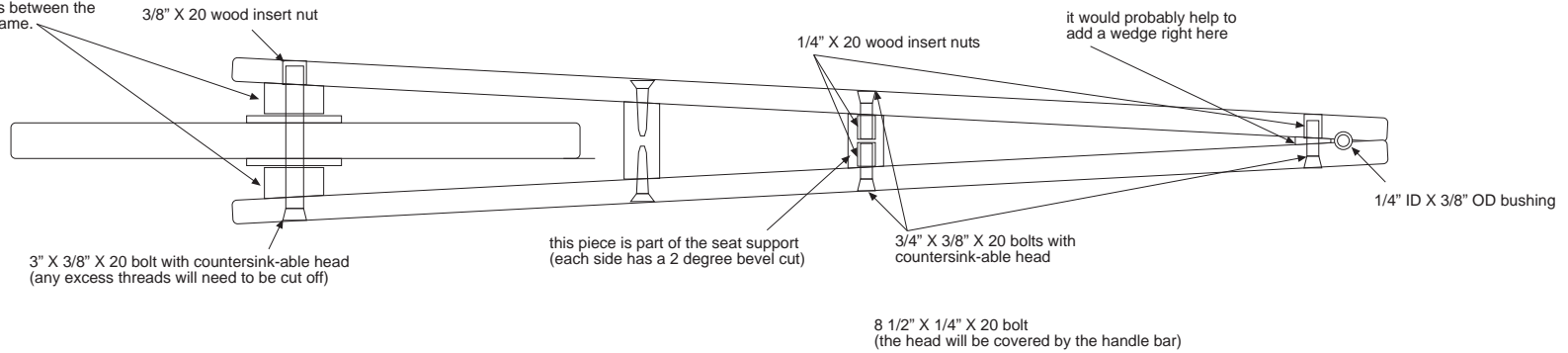

(These three wedge-shaped pieces are not in the patterns because they're essentially straight cuts with beveled edges (to match the angle formed by the two halves of the frame.)

# The Front Fork

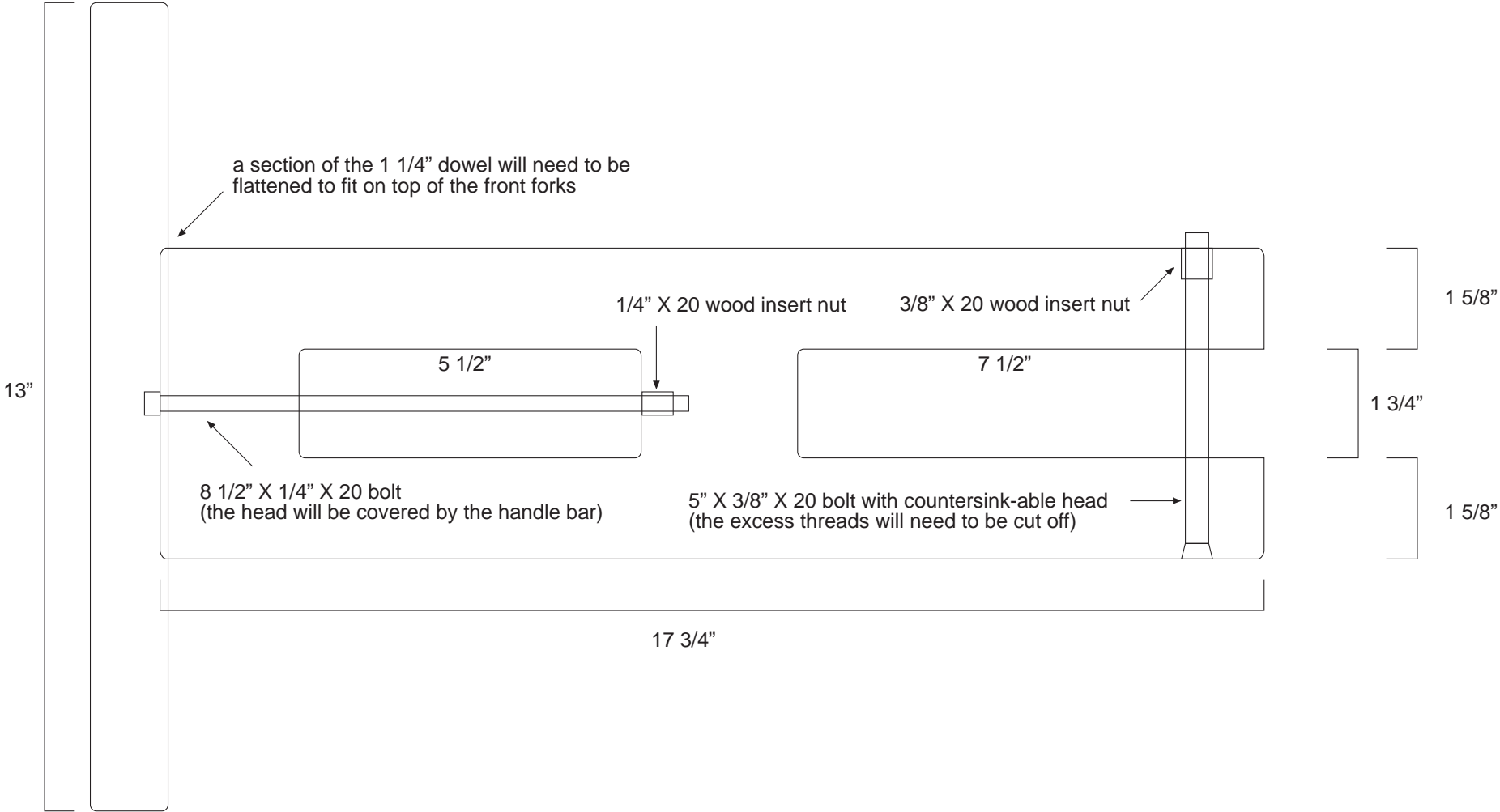

# The Wheels

